

Breadboard Electronics

—

PT-Tinker

Common Components

You'll see these components over and over.

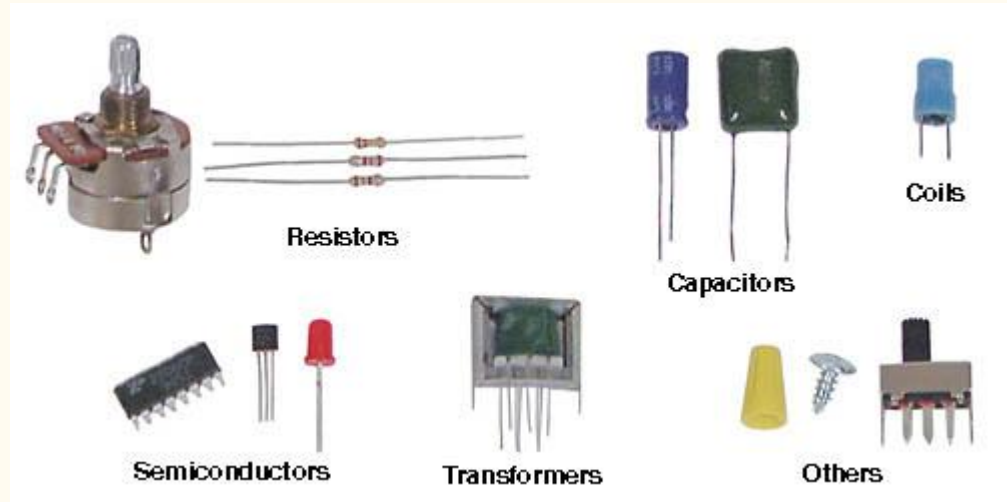

Wiring

Electronic devices work by letting electricity flow in controlled ways through components connected together by wiring.

The wiring lets the electricity get from one component to another.

For wiring you can use actual wires, printed circuit boards (called “PCBs”), a breadboard or some combination.

We’re going to use a breadboard and some wires.

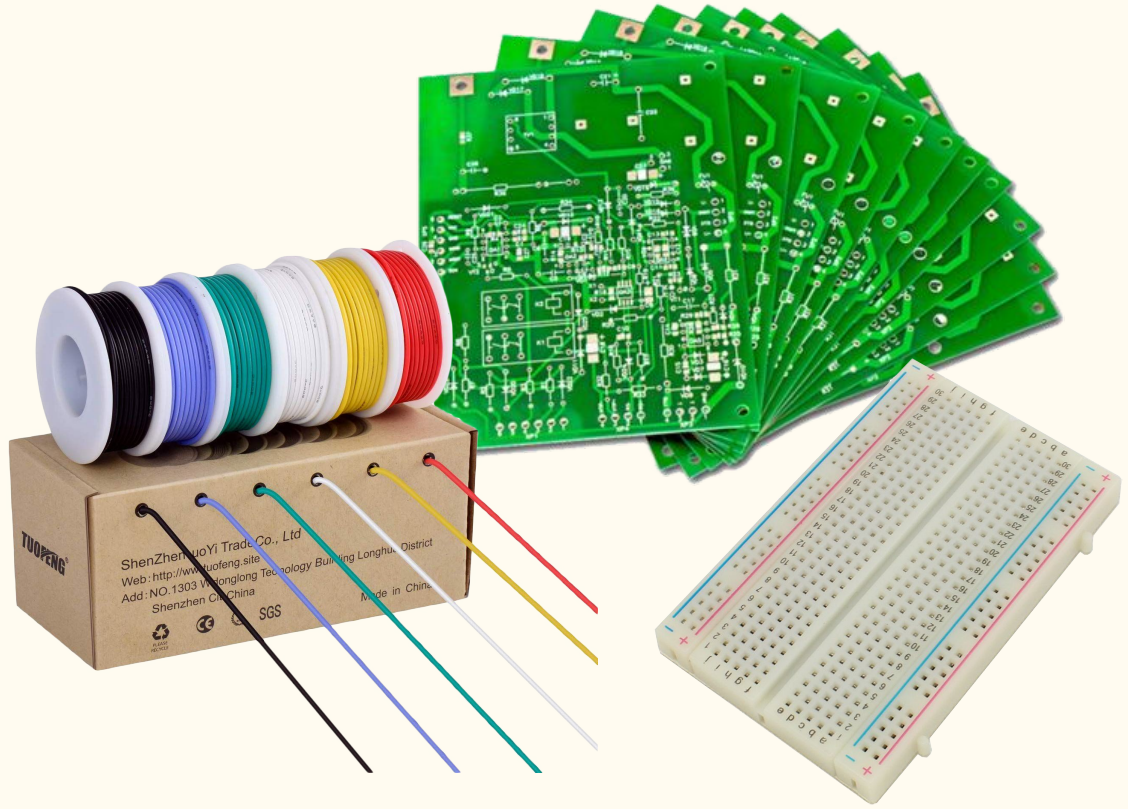

Breadboards and Jumper Wires

A breadboard is great for experimenting with electronic devices. It's quick and convenient. You just push the wires coming out of the components into holes in the breadboard and then use wires called "jumpers" to connect them together.

But breadboards are not good for permanent builds because it's easy to knock components or jumpers loose.

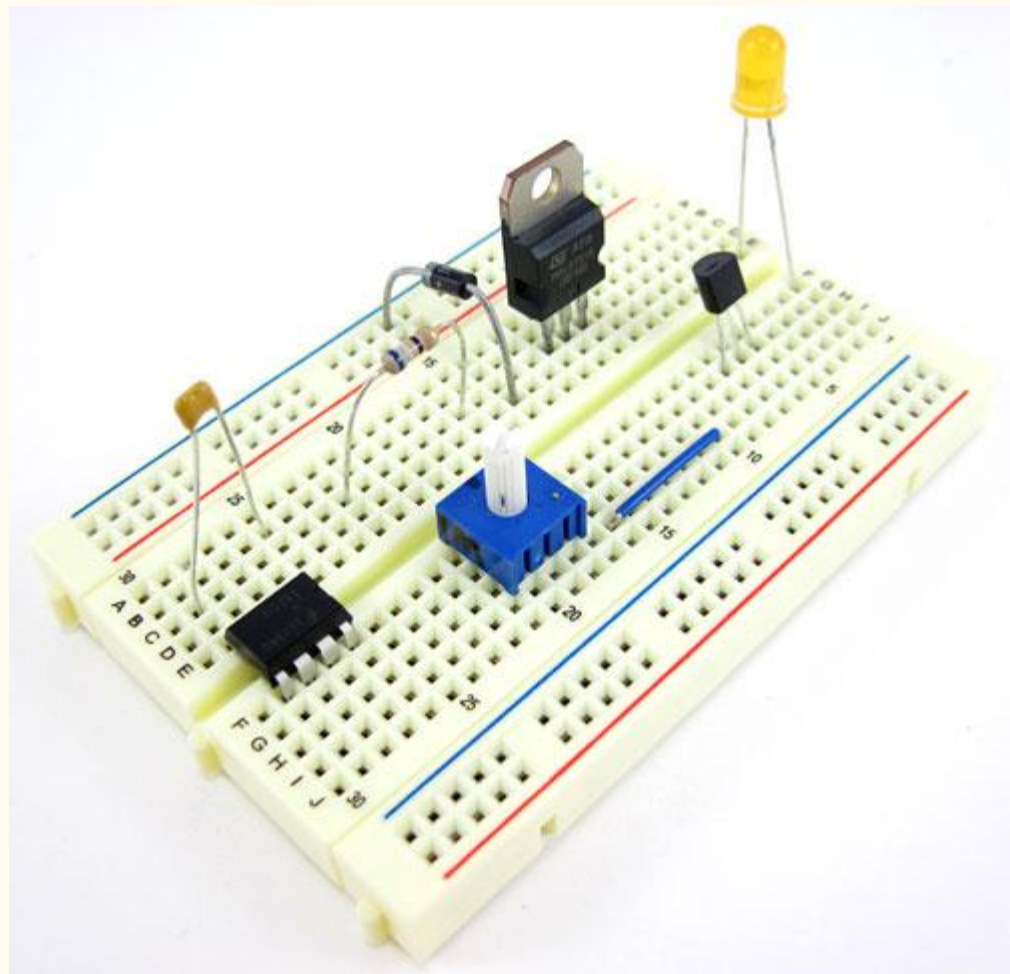

Inside a Breadboard

In breadboards, the holes are connected together in a standard way.

The yellow lines show which holes are connected together. For example, in row 1 (at the top) the holes A through E are all connected to one another.

Usually builders connect the long columns marked “+” and “-” to a supply of electricity, like a battery. Then they plug the other components into holes in the center of the board and use jumpers to go from one set of holes to another.

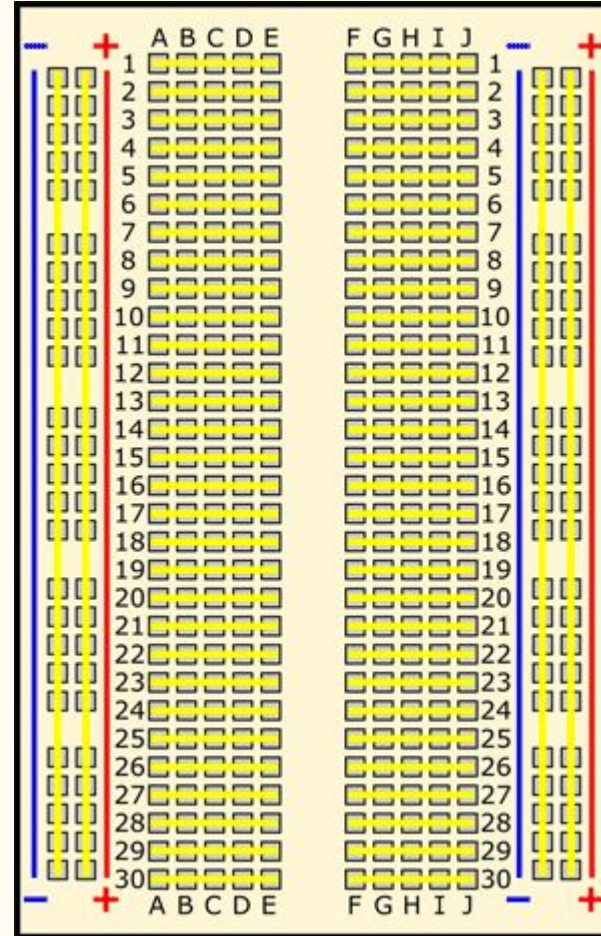

Breadboard Diagrams

We use breadboard diagrams to show how the components and jumpers are connected to one another on the breadboard.

This diagram shows how to make an LED light controlled by the switch on the battery case.

These diagrams are nice because they look pretty much like the real breadboard, components, and jumpers. But there's another form of diagram that's easier to draw. And, super important, they let you understand what's going on.

Diagram

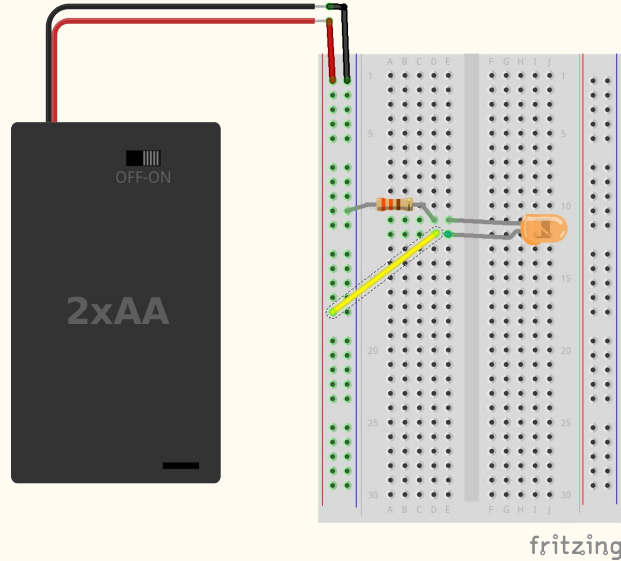

Real Breadboard

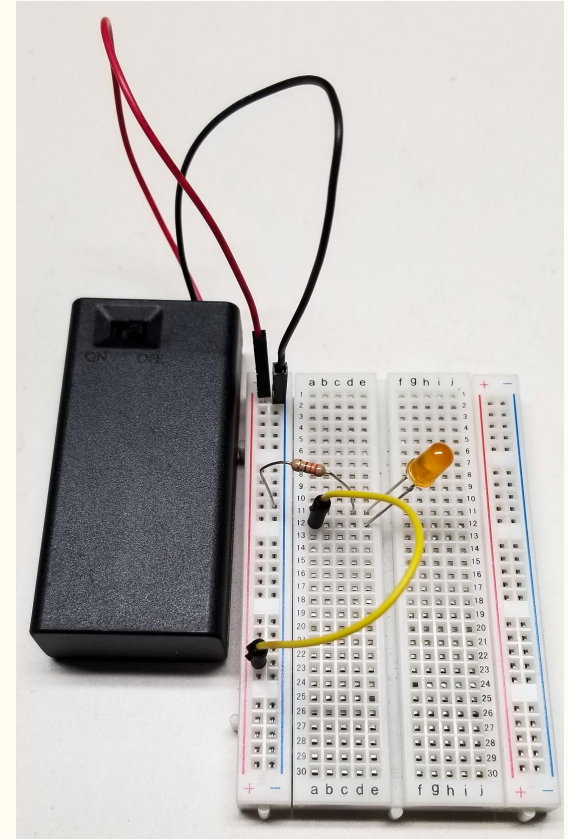

Schematic Diagram

Schematic diagrams (or just “schematics”) use symbols and lines to show what components you need and how to wire them together.

Schematics don't show where on the breadboard the components go, just how they hook together. You can arrange them however seems easy to you, so long as they connect together as shown in the schematic.

Schematics are nice because, when you know how to read them, you can figure out how things work.

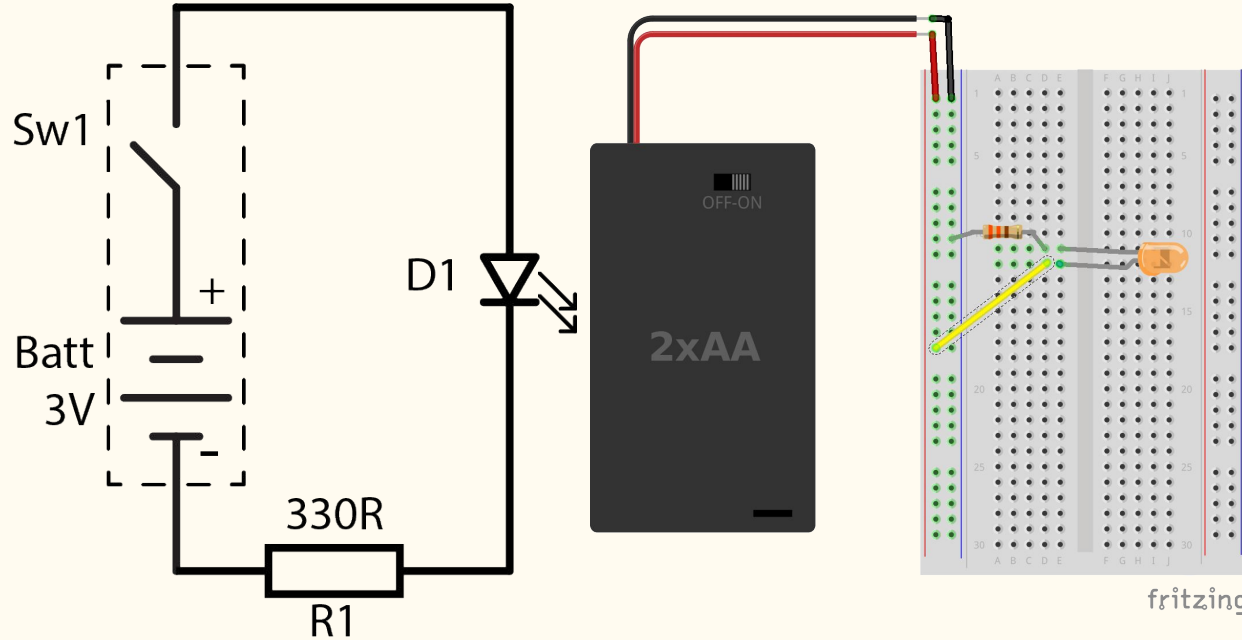

Schematic Diagram

The schematic makes it clear that what we have is a circuit -- a closed loop from the battery, through the components and back to the battery. That's harder to see in the breadboard. Let's see how to read it.

The first symbol is the switch (Sw1). It looks and acts like a drawbridge. Turning on the switch lowers the drawbridge lets the electricity flow across it. When it's up, the electricity can't go anywhere, so nothing happens. It just stays in the battery.

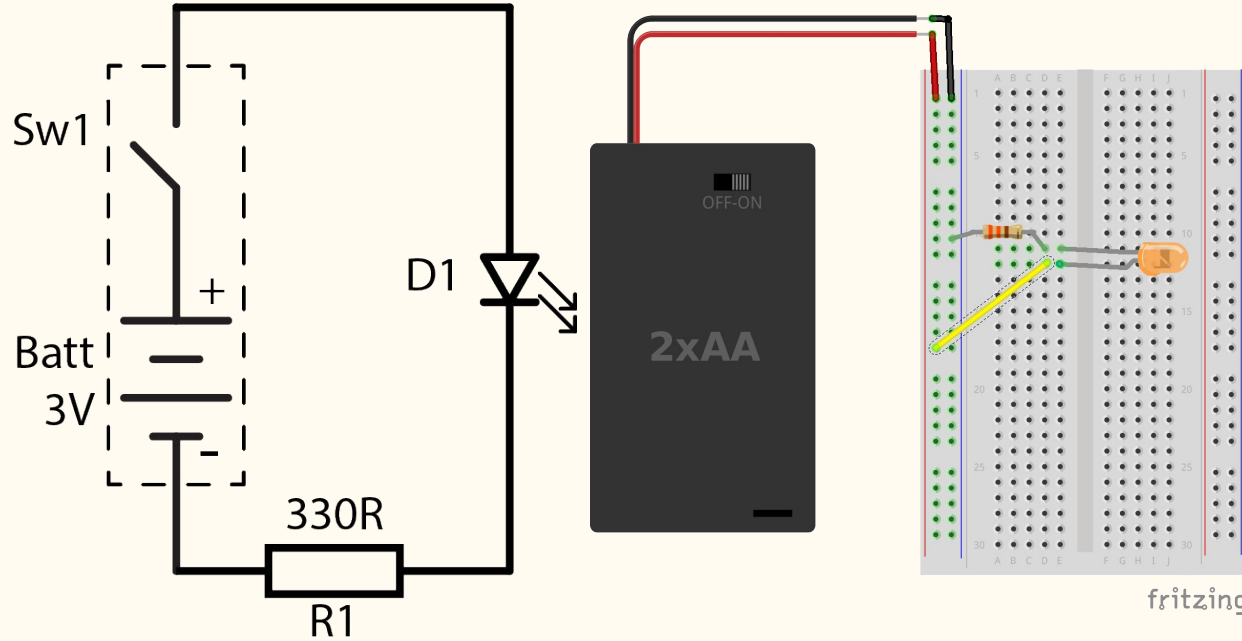

Schematic Diagram

When you turn Sw1 on, the drawbridge lowers and electricity from the battery's + side flows through the switch, around the top of the schematic, through LED (D1), making it light up (the little arrows). It then goes through the resistor (R1) and back to the battery, completing the circuit. For electricity to flow, it has to make it all the way around.

This is hard to see with the breadboard. In the picture, the battery and the switch are inside the box. The red wire is attached to the top of the switch.

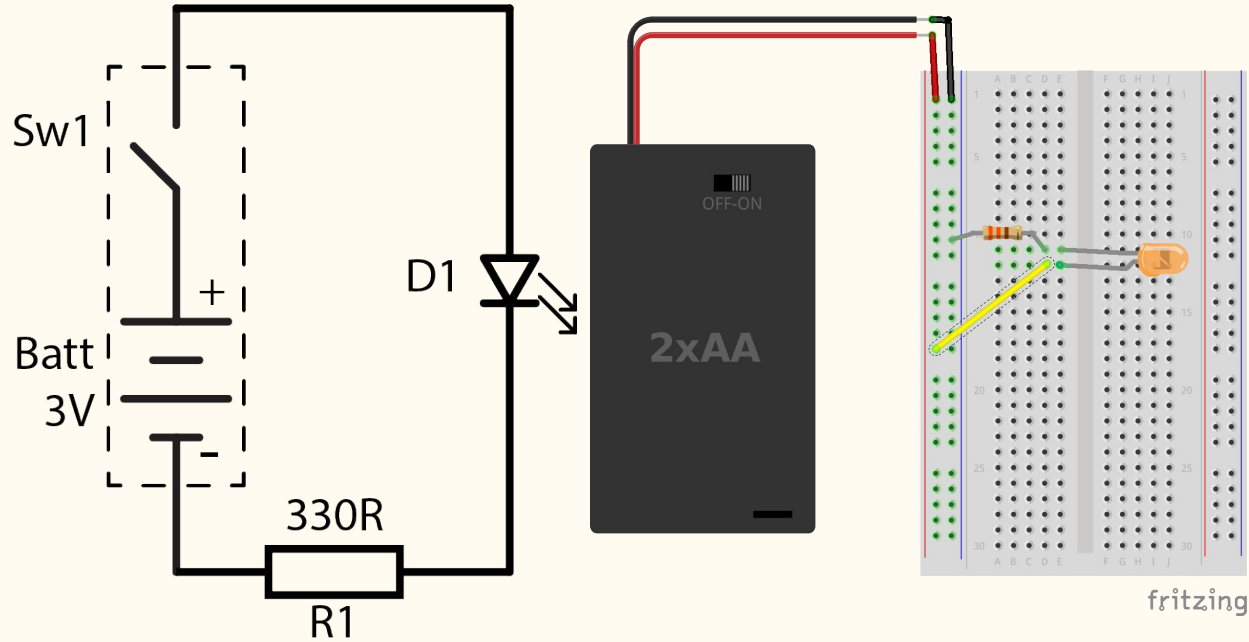

Schematic Diagram

When you turn the switch on, electricity flows from the battery through the switch and out along the red wire. It goes down the column on the breadboard to yellow wire. It flows through the wire and up one lead to the LED. It goes through the LED, lighting it up. The electricity then goes down the other lead to the breadboard. Next it goes through the breadboard to the resistor, through the resistor, up the breadboard column, through the black wire and back to the battery.

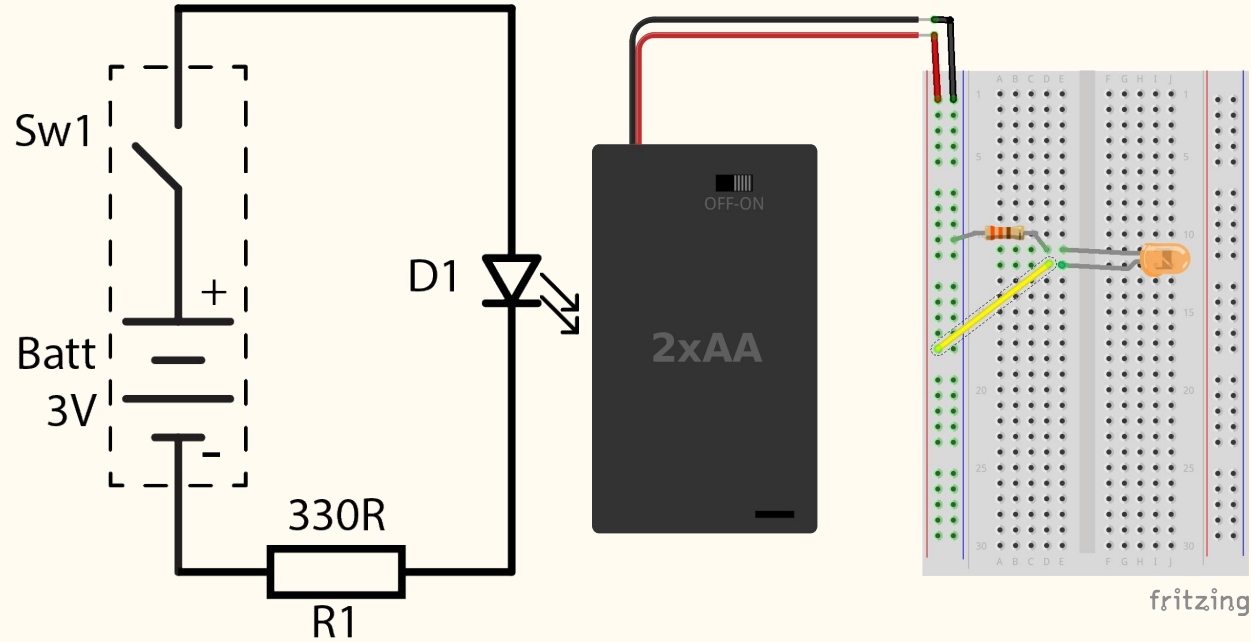

All that's much easier to see in the schematic!

Let's make an LED light

You'll need the components shown at the right. You'll also need a breadboard and, probably, a few jumpers.

See if you can read the schematic on the next page to build the LED light. Once you have it all hooked up, when you push the switch to "ON," the LED should light.

If it doesn't light, you've got a "bug." Check everything and try again. Finding and fixing bugs is normal. Keep at it: You'll figure it out!

Battery Pack and Switch

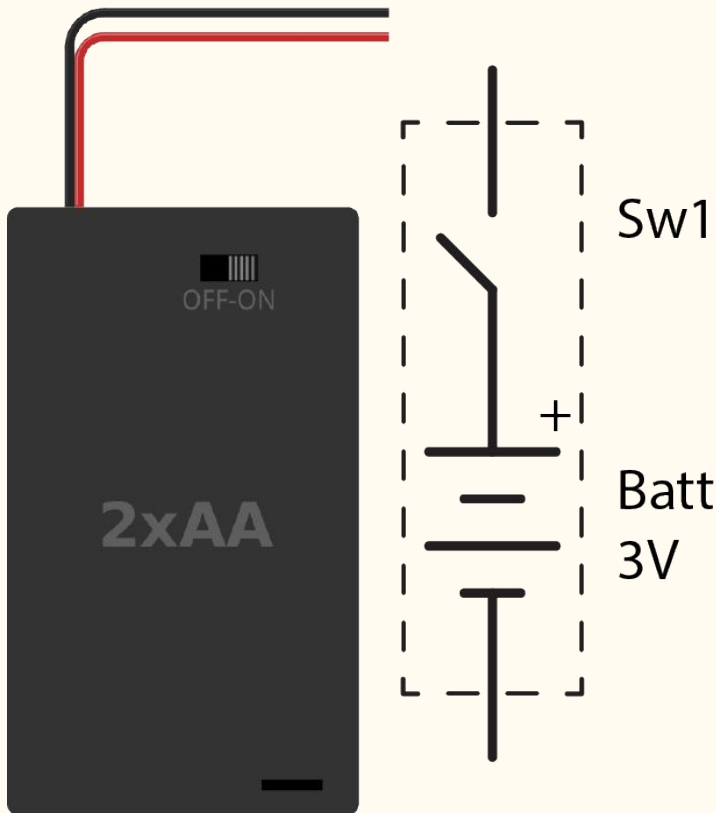

Resistor

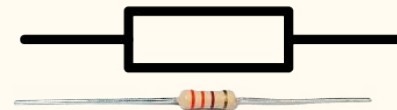

See reference pages for resistor color codes

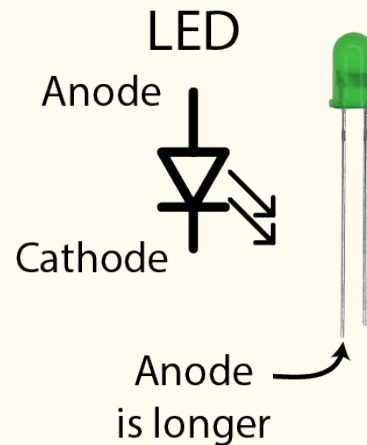

Things to know

The switch and the battery are in the black box. The red wire goes inside to the switch. The black wire goes inside to the negative terminal of the battery -- at the bottom in the schematic.

The LED will only work if it's hooked up the right way around.

The resistor resists equally well in either direction. But it does matter how much it resists -- what value it has. You want one that's 330 Ohms. Resistors have color bands that tell their value. Use the chart in the reference material to decode them.

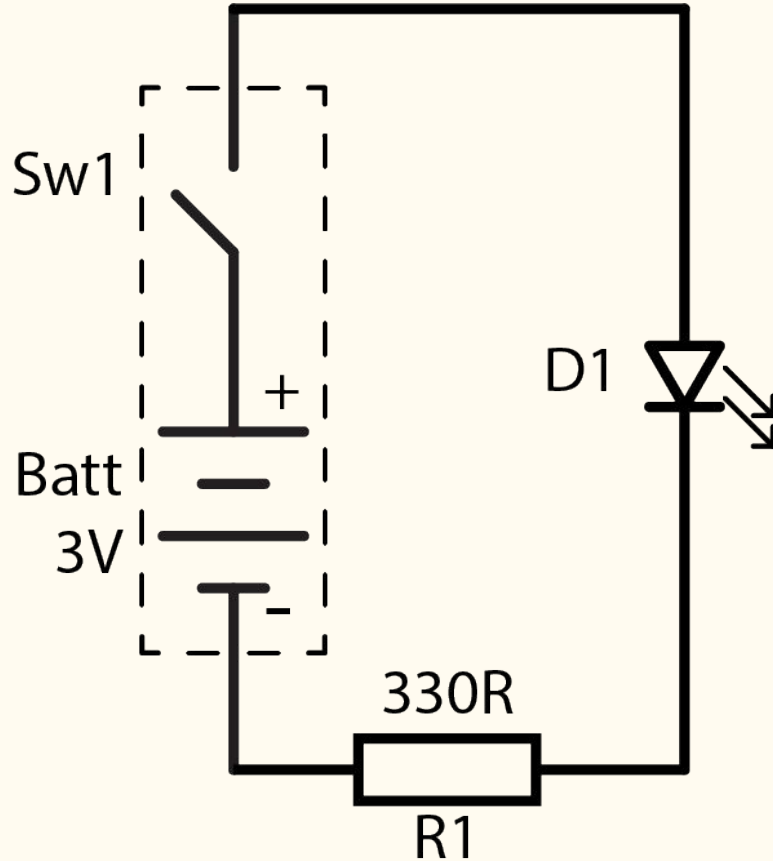

Dark Detector

Let's make the LED come on automatically when it gets dark.

We'll need to add three more components. First, a phototransistor. It works like a switch controlled by light — when it sees light it turns on and lets electricity pass. Second, a transistor. It's a switch controlled by electricity on its base. It turns off when the phototransistor turns on. And a resistor to limit the electricity going through the transistors.

Can you add these to your LED circuit?

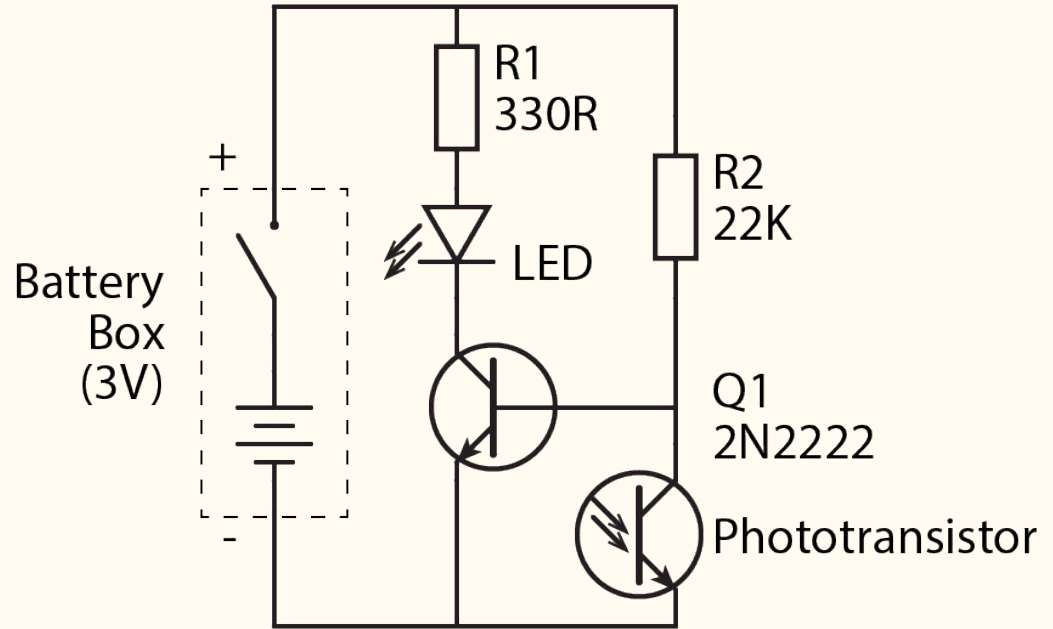

2N2222 Transistor

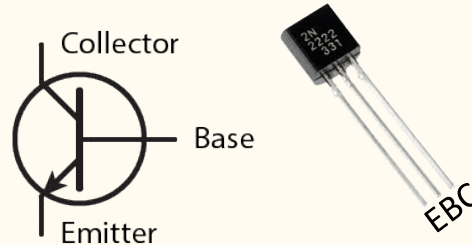

Phototransistor

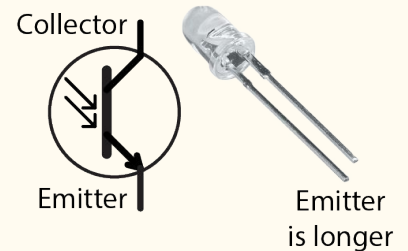

Flip-Flop

For our last project let's make one of the most important digital circuits: a flip-flop. It has two transistors arranged so that when one is on the other is off. If we wire it up right we can make them take turns being on. And by adding an LED to each, we can make "blinky lights." Everybody likes blinky lights!

What controls how fast the lights blink? Hint: capacitors store electricity and resistors resist it. If you charge a capacitor through a resistor it takes a while to fill up. A bigger capacitor takes longer to fill up because it holds more.

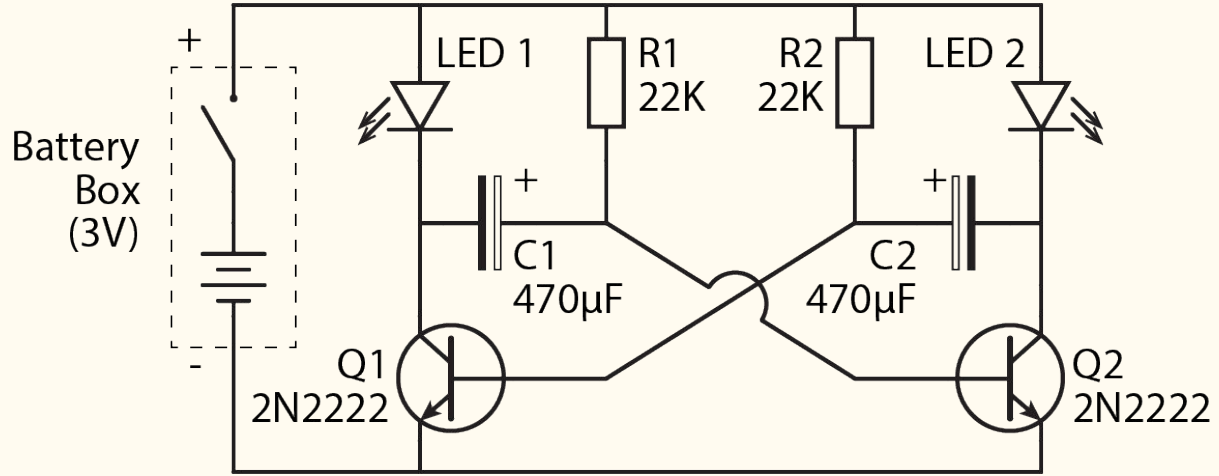

The only new kind of component in the flip-flop is the capacitor.

White stripe with "-" tells which leg is negative.



Printing tells the capacitor's value. (470µF, max 25 volts)

- +

Reference Material

—







Resistors

Resistor Symbols

Schematics show components using symbols. The symbols are labeled to indicate important electrical characteristics.

Resistors, as their name implies, resist the flow of electricity. How much they resist it is measured in Ohms, the symbol for which is the Greek letter Omega (Ω).

Many symbols have “old school” alternatives. They’re just a different way of drawing the same thing.

	1M5	1,500,000 Ω = 1.5M Ω
	1M	1,000,000 Ω = 1M Ω
	1k5	1,500 Ω = 1.5k Ω
	1k	1,000 Ω = 1 k Ω
	330R	330 Ω
	1.5meg	Old School

Resistor Color Codes

Resistors resist the flow of electricity. How much a resistor does this is measured in “ohms.” The more ohms, the more it resists. Values range from 0 ohms through thousands (kiloohms) to millions (megohms).

The value of a resistor is shown by bands of color on the body. There are two variations. One with four bands, and one with five.

In both sorts, the first bands tell the value and the last band tells how precise the value is.

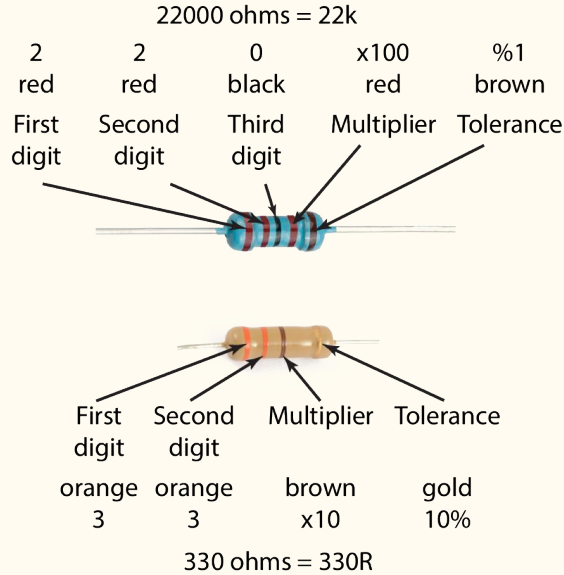

Digit	Color	Multiplier	Tolerance
0	Black	x1	
1	Brown	x10	1%
2	Red	x100	2%
3	Orange	x1k	
4	Yellow	x10k	
5	Green	x100k	0.5%
6	Blue	x1M	0.25%
7	Violet	x10M	0.1%
8	Gray	x100M	0.01%
9	White	x1G	
	Silver	x0.1	5%
	Gold	x0.01	10%
	None		20%

Capacitors

Capacitor Symbols

Capacitors store electricity. How much electricity they can store is measured in Farads. One Farad is a whole lot, so capacitors are often a tiny fraction of a Farad.

1 Farad = 1,000,000 microFarads (μF)
1 microFarad = 1,000 nanoFarads (nF)
1 nanoFarad = 1,000 picoFarads (pF)

Sometimes you'll see people get "stuck" on microFarads, so instead of saying a capacitor is 10nF they'll say it's 0.01 μF .

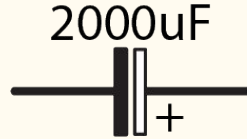

2,000 microFarad = 0.002 Farad

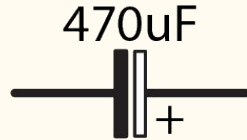

470 microFarad = 0.000470 Farad



470 nanoFarad = 0.000000470 Farad



470 picoFarad = 0.000000000470 Farad

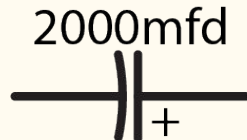

Old School

Inductor Symbols

Inductors resist a change in the flow of electricity -- up to a point. As electricity starts to flow, they push back by storing energy as a magnetic field. If the change slows down, they take energy from the magnetic field to add to the flow.

Inductors are also called “coils” because they really are coils of wire wrapped around something.

Inductance is measured in Henrys. Most of the time you’ll see milliHenrys (mH) and microHenrys (uH).

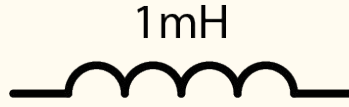

1 milliHenry

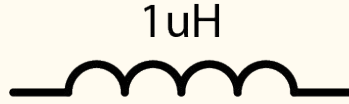

1 microHenry



Air-core: Wound on a paper tube



Iron-core: Wound on a piece of iron



Ferrite-core: Wound on a piece of ferrite



Old School

Switch Symbols

Switches look like little drawbridges. When the bridge is down, the switch lets electricity through, when it's up, it doesn't.

There are lots of kinds of switches. You can usually figure out who they work just by looking at them.



Single pole, single throw



Single pole, double throw



Double pole, single throw

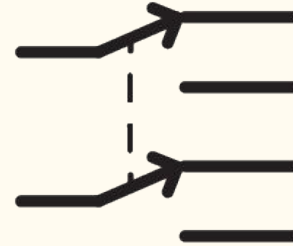

Double pole, double throw



Push button

Batteries

Battery Symbols

Batteries are represented by long and short lines, each pair representing one cell in the battery. The long line is the positive terminal, and the short one the negative.

Because different kinds of battery chemistry give different voltages, battery symbols usually explicitly show the voltage.

